

SPADE ORIENTATION VIEW

REVISIONS					
REV	DATE	ECN #	DESCRIPTION	BY	APPD

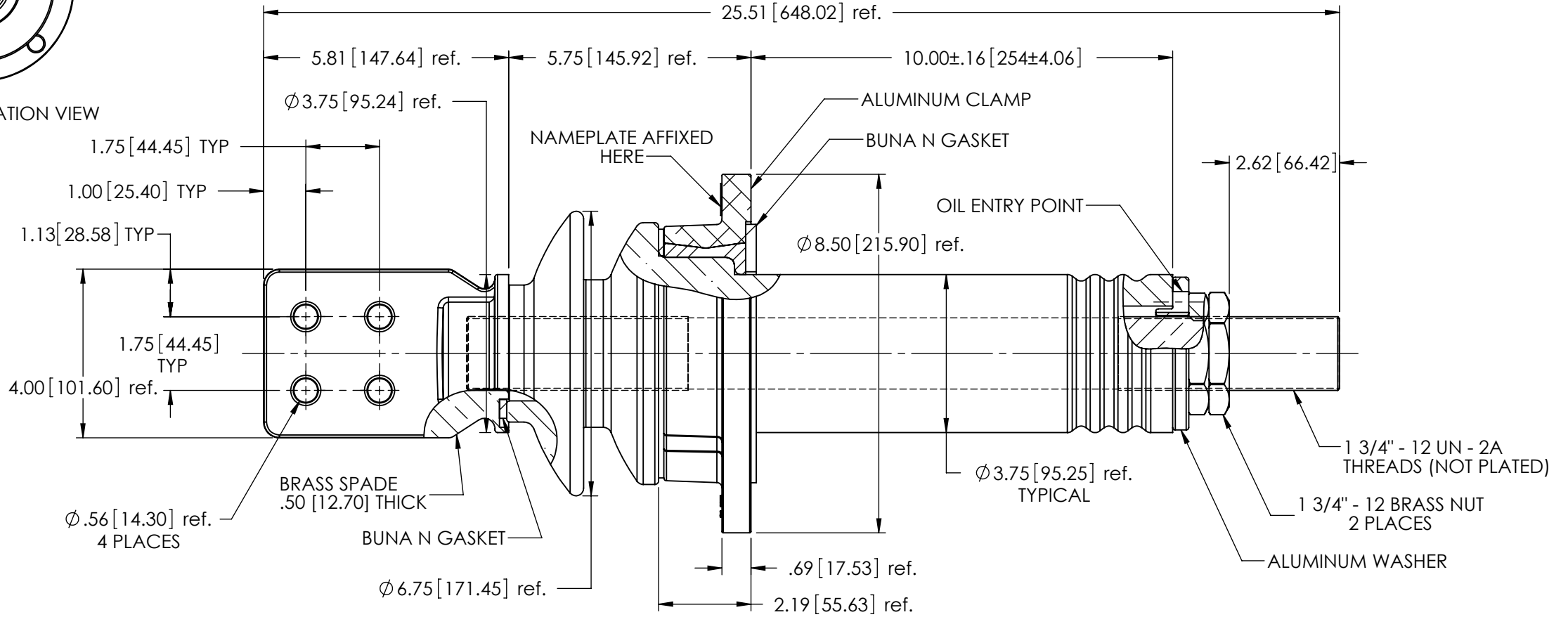

**MOUNTING HOLE NOTE:**

1. LOCATED ON A  $\phi 7.25$  [184.15] ON THE ALUMINUM CLAMP.
2. FOUR (4) THRU HOLES AT  $\phi .688$  [17.46] EQUALLY SPACED 90° APART.

**MATERIAL:**

STUD - COPPER C11000  
 SPADE - C84400 TIN PLATED

**NOTES:**

1. SHANK TO FIT INTO  $\phi 4-1/4$ " TANK HOLE.
2. FOR HORIZONTAL OR VERTICAL MOUNTING.
3. MINIMUM COLD OIL LEVEL - 4" UP SHANK.

**PORCELAIN NOTES:**

1. WET PROCESS ELECTRICAL PORCELAIN.
2. GRAY GLAZE MUNSELL 5BG 7.0/0.4
3. TOLERANCE  $\pm 3\%$  WITH NOTHING LESS THAN  $\pm .03$ ", UNLESS OTHERWISE NOTED ON DRAWING.

**SPECIFICATIONS:**

1. VOLTAGE RATING ..... 5kV CLASS
2. BASIC IMPULSE LEVEL ..... 75kV BIL
3. NOMINAL CURRENT RATING ..... 2406 AMPS @ 1000A / SQ.-IN.
4. CREEP DISTANCE (MINIMUM) ..... 6.38 [162.05]
5. STRIKE DISTANCE (MINIMUM) ..... 4.16 [105.66]
6. APPROXIMATE WEIGHT ..... 38.18 LBS

**PROPRIETARY AND CONFIDENTIAL**  
 THE INFORMATION CONTAINED IN THIS DRAWING IS THE SOLE PROPERTY OF H-J ENTERPRISES, INC. ANY REPRODUCTION IN PART OR AS A WHOLE WITHOUT THE WRITTEN PERMISSION OF H-J ENTERPRISES, INC. IS PROHIBITED.

**TOLERANCES (EXCEPT AS NOTED)**

DECIMAL	.X" = $\pm .1$ " .XX" = $\pm .06$ " .XXX" = $\pm .03$ "
ANGULAR	+/- 1 Degrees



H - J ENTERPRISES, INC.  
 3010 HIGH RIDGE BLVD. HIGH RIDGE, MO. 63049 USA  
 PHONE 1-636-677-3421 FAX 1-636-376-1915

**5 kV CLASS POWER BUSHING**

MATERIAL (SEE DRAWING)

CHK'D	APP'D	DRAWING NO.
		AS1709-0011

DRAWN BY SMM

DATE 10/5/2012

SCALE N.T.S.